

Emergency Power Pack (EMP)

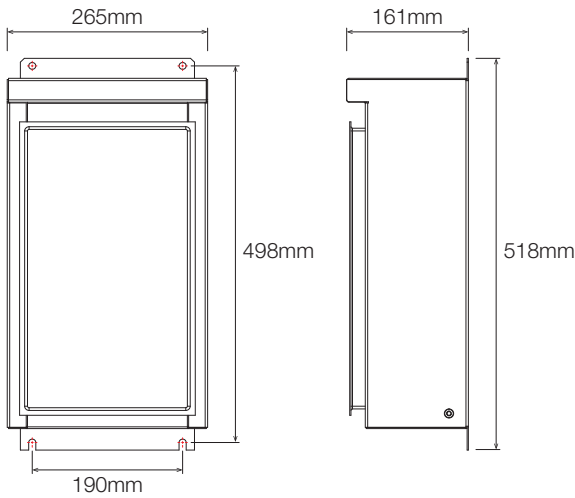

⚠ ATTENTION:
Isolate mains supply externally before conducting any work.

NOTE:
 Mains connection to either terminal will energise both terminals.

RISK OF SHOCK:
 During fault condition mains must be connected and the battery isolation switch must be in the ON position for the error indicators to be accurate.

Electrical Characteristics		
Voltage In 120 – 277 VAC, 50/60 Hz	Power 100W	Power Factor 0.95

Battery Details

Unit only designed to operate using either LEAD CRYSTAL® or VRLA batteries. Recommended battery listed below. Contact Coolon for replacement batteries.

MANUFACTURER	MODEL	CAPACITY
Betta Batteries	6-CNFJ-7.2	12V, 7.2Ah/20HR

Emergency Pack Operating Modes

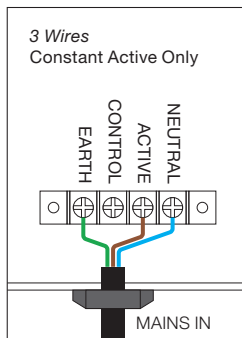

NON-MAINTAINED
Emergency use only

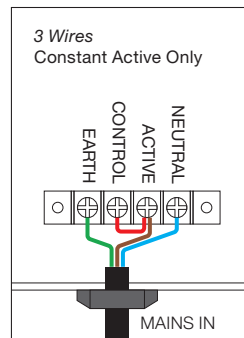

MAINTAINED
Always ON

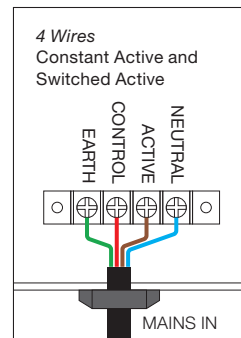

SWITCHED
Conventional luminaire use with emergency backup

ACTIVE	CONTROL	OPERATION STATE	DESCRIPTION
ON	OFF	Default (Non-Maintained)	Luminaire turned OFF. EMP Charge Monitor will indicate mains presence with Red Indicator LED on.
ON	ON	Default (Maintained)	Luminaire switched ON at full brightness (Maintained Operation).
OFF	OFF	Emergency Operation	Emergency state, where power disappears from the active terminal. Luminaire will be switched ON, powered by batteries. EMP Charge Monitor will turn off.

Emergency Pack Operation

- Once the EMP is connected to mains the Red Indicator LED on the lid will illuminate to indicate mains presence.
 - If the Indicator LED is flashing, check that the battery isolation switch is in the "ON" position.
 - If the battery isolation switch is in the "ON" position and the Red Indicator LED is still flashing, see the EMP TROUBLESHOOTING section for further details.
- Pressing the "TEST BUTTON" on the lid will disconnect the mains simulating a power outage. The Red Indicator LED will stop illuminating and the EMP will operate in emergency mode if the battery isolation switch is in the "ON" position.
- Critical system fault is indicated by the flashing Red Indicator LED during mains voltage presence. See the EMP TROUBLESHOOTING section for further details.

Commissioning Test

Once energised allow up to 10 seconds for the EMP controller to go through the self-test procedure.
 Batteries are labeled with their last charge date. If the batteries have not been used more than 3 months, they have to cycle 2–3 times to restore their capacity.
 A typical cycle includes a 16 hour charge followed by a complete discharge.
 Properly operating batteries operate Coolon Emergency Luminaires for a minimum of 2 hours in the absence of mains power.

Emergency Pack Troubleshooting

On-board processor monitors the state of the EMP modules and periodically checks the batteries. Internal operations and fault conditions are signaled by on-board LEDs. Critical Fault will cause external Indicator LED to flash.

Error Code	■	RED LEDs (Internal Fault Indicator) Internal RED Fault indicator LEDs used for internal diagnostics. LEDs indicate internal faults using binary codes.
Error Code	■	In the event external Indicator LED is flashing, information about the internal LED status may help diagnostic and fault rectification on-site. Contact COOLON support (support@coolon.com.au) for guidance.
Charger 2	■	GREEN LEDs (Operating Mode Indicator) MAINS VOLTAGE LED will illuminate when mains is present.
Charger 1	■	CHARGER 1 and CHARGER 2 LEDs flash during charge and stay ON once the individual respective batteries are fully charged.
Mains Voltage	■	

Battery Replacement Procedure

1. Isolate mains supply to the EMP.
2. Put isolation switch to "OFF" position.
3. Disconnect the spade terminals from the batteries.
NOTE: Do not use any conductive material to remove the terminal connector.
4. Loosen the top then the bottom battery housing keeping the captive screws within the housings.
5. Remove the batteries and insert new batteries.
NOTE: Fit the rubber battery tray to the new batteries before installation.
6. Tighten the bottom then the top battery housing. The batteries should sit snug with the battery housing flat on the base.
7. Carefully connect respective spade terminals observing battery polarity.
NOTE: Black wire always connects to negative terminal of the battery.

Battery wiring diagram is provided on the right

⚠ CAUTION

- Do not short circuit the battery terminals
- Dispose of the used batteries in accordance to State Law

Battery Dimensions

