

This manual is applicable to Coolon EMP units in the 0036AL enclosure, which do NOT currently have any breathers/vents fitted.

Tools Required

- Drill/driver
- 5mm hex bit
- 4 to 12mm step drill bit (or a 4mm and 12mm drill bit)
- Deburring tool/bit
- Gore vent (provided by Coolon)
- High capacity breather valve (provided by Coolon)

Wear Personal Protective Equipment

The following is minimum PPE required for this task, additional PPE may be required based on site requirements.



⚠ ATTENTION:

The purpose of this procedure is to provide safe work instruction to relieve the potentially trapped hydrogen (H₂) gas inside the EMP enclosure. Whilst the probability of having a volatile level of hydrogen is extremely low, we urge all operators to follow the outlined procedure as it is designed to allow safe operation even at the highest levels of hydrogen concentration.

Potential hazards	Risk rating	Control measure(s)
Low concentration hydrogen ignition	Low	Gas ignition is an unlikely event. If the gas was ignited it would push the gas out past the seals at the perimeter of the enclosure. A hissing sound may be audible. A operator standing an arm's reach in front of the unit would be safe.
High (maximum) concentration hydrogen ignition	Low	Gas ignition is an unlikely event. The generation of this volume of gas is also very unlikely. If the gas was ignited it would rupture the front of the enclosure deforming the front cover and possibly swinging the cover open. Ignited gas would be directed mainly to the right away from the enclosure when facing the EMP. A loud sound similar to an engine backfire will be audible. A operator standing an arm's reach in front of the unit would be safe.
Electric shock	Low	Site electrical isolation procedures should be following in conjunction with the procedure outlined below.

Installation Instructions

Step 1

Power down Emergency Pack by switching off its mains supply line. Both Mains supply and Control line should be de-energised.

Do not press the TEST BUTTON on the EMP lid.

Emergency Pack will enter Emergency Mode, which turns the EM luminaire ON and "MAINS POWER" LED indicator on the EMP lid OFF, discharging the battery.

Check that every EM Luminaire is ON. Battery will be discharged down to 10.5V under load before the load is automatically disconnected.

Wait for the EM luminaire to switch OFF before going to the next step. Completely charged batteries could provide up to 4 hours of emergency operation at their initial state. Keep the mains line and control line de-energised. This removes a potential source of ignition being relay contacts as there will be no more voltage / current across the contacts.

Step 2

Disconnect the load from the EMP by removing the twist lock connector.

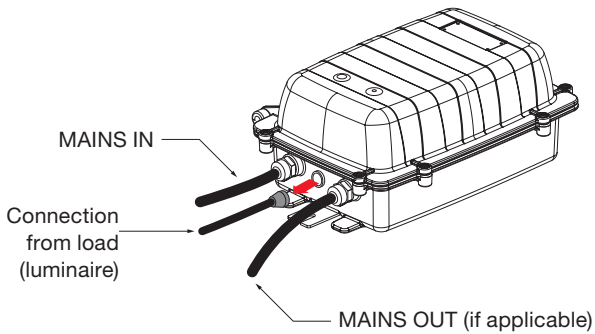

Step 4

Switch the 'Battery Isolation' switch to the OFF position.

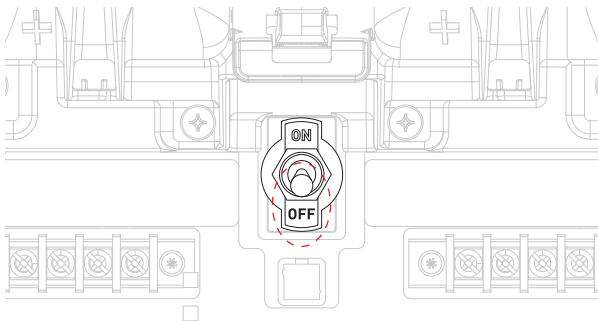

Step 6

Install the Gore vent with the star washer on the bottom of the EMP enclosure lid. The torque should be between 2.0-2.4Nm.

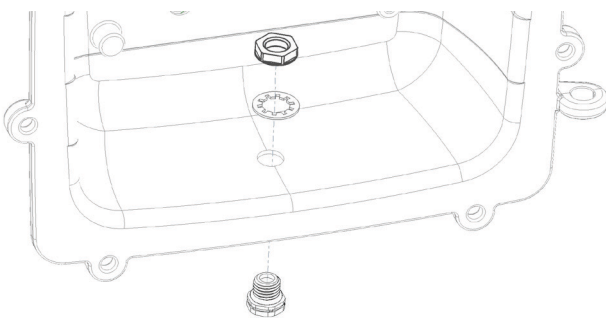

Step 8

Close the lid and fasten the 8 socket head cap screws and reconnect the load.

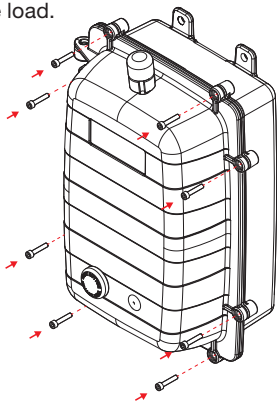

Step 3

Emergency pack enclosure screws (8 in total) can now be undone allowing the cover to be opened.

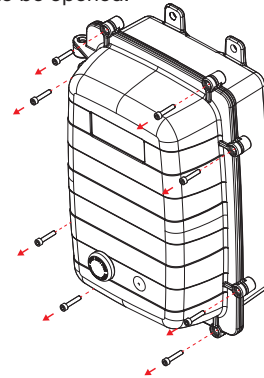

Step 5

Drill and install the High Capacity Breather Valve on top of the EMP enclosure lid.

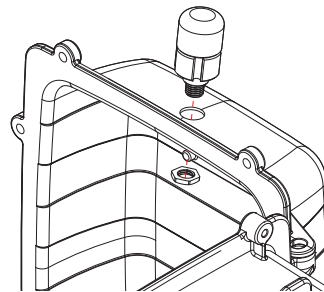

Step 7

Switch the 'Battery Isolation' switch to the ON position.

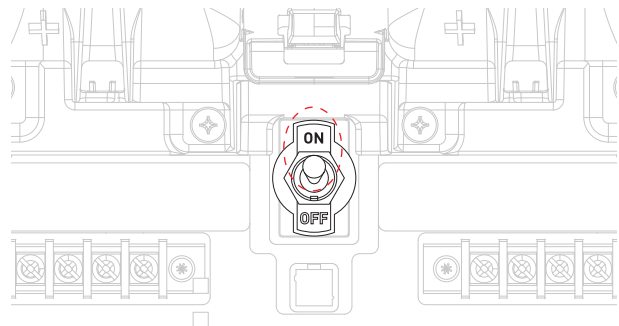

Step 9

Re-energise the EMP

- 9.1. Allow at least 16 hours of uninterrupted charge time to charge the batteries to a suitable capacity to undertake any in-service test.
- 9.2. Once the batteries are recharged the site may wish to test their capacity by switching of the mains supply and observing a minimum of 90min or EM luminaire operating time.
- 9.3. Should any EMP detect any battery or controller fault once the EMP is re-energised the RED LED indicator on the cover of the EMP will flash on-off indicating the unit requires attention.