



ROM HOPPER BIN INDICATOR

Depth / Distance Indicator Light

Visual guidance indicators for reversing dump trucks

Speeds up the dumping cycle by assisting dump truck drivers to reverse rapidly without colliding with the walls of the ROM bin.

While reversing the truck into the ROM hopper, only the blue vertical LEDs and the green horizontal LEDs should be visible to the driver in the onside mirror. When this is observed, there is sufficient room between the offside edge of the hopper and the truck. If the orange and/or red LEDs are visible, the driver is warned that the offside of the truck tray is getting too close to the offside of the hopper.

The Rom Hopper Bin Indicator features an ambient light sensor which adjusts the brightness of the LEDs automatically in order to be clearly visible during the day and not blind the driver at night time. This feature can be tuned for specific applications with a brightness setting adjustment located inside the power supply.

Designed for use in:

- Hopper Bins
- Rom Bins
- Other Safety Indicators



Faster and safer reversing every time

The ROM Hopper Bin Indicator bars are widely used by the Iron Ore industry across Australia. This simple, yet effective navigation system helps to continuously improve circuit turnaround time and save cost of accident related down time.

Improve safety, productivity & reduce driver fatigue

The ROM Hopper Bin Indicator is an intricate solution that has been proven for many years to provide successful results. It allows the driver to quickly and effortlessly align the dump truck whilst reversing into the bin.



REVERSE DAYLIGHT SENSOR

This product is fitted with intelligent light sensor. The LED light intensity is increased during the day, to maximize the effectiveness in the bright desert conditions and reduced with the nightfall to avoid blinding truck drivers.



COOL SURFACE TEMPERATURE

Coolon's Industrial LED fittings have a much lower surface temperature than traditional HID equivalents which prevents dirt from baking onto the luminaire. This allows for easier cleaning and will prolong the lifespan of the luminaire.



LONG USEFUL OPERATING LIFE

At Coolon we believe the lifetime of a luminaire is so much more than just the LED's. Coolon product lifetime takes the entire luminaire into consideration and each product is backed by a comprehensive warranty – that's the Coolon confidence.



3 YEARS FACTORY WARRANTY

Coolon Luminaires are covered by a solid comprehensible manufacturer's warranty that covers a range of possible defects and performance parameters throughout the duration of the warranty period.



LOW SUSCEPTIBILITY TO VIBRATION

This luminaire is designed to handle continuous exposure to vibration. A typically critical issue affecting the life and operation of most common gas discharge lamp based light sources is mechanical shock and vibration.



NO FLICKERING

LED luminaires run on constant low voltage DC power and do not produce any visible stroboscopic effects, thus reducing the strain on eyes and significantly improving safety in areas where moving machinery is present.



HIGH IP RATING - IP66

Coolon's Industrial LEDs are designed specifically to withstand the harsh conditions in mining environments. The robust design allows our LED products to be used in many different applications and are high pressure washable.



PROUDLY MADE IN AUSTRALIA

Engineered to perfection, using only the highest quality components and highly skilled labour, each luminaire is assembled and thoroughly tested to ensure that it exceeds the highest standards.

DIMENSIONS

ROM Hopper Bin Indicator Bar

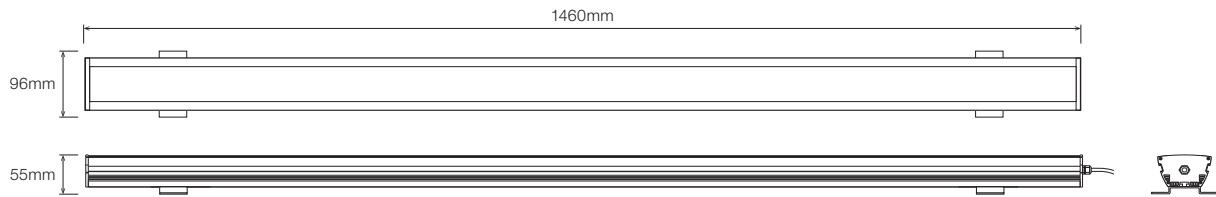

Standard Power Supply

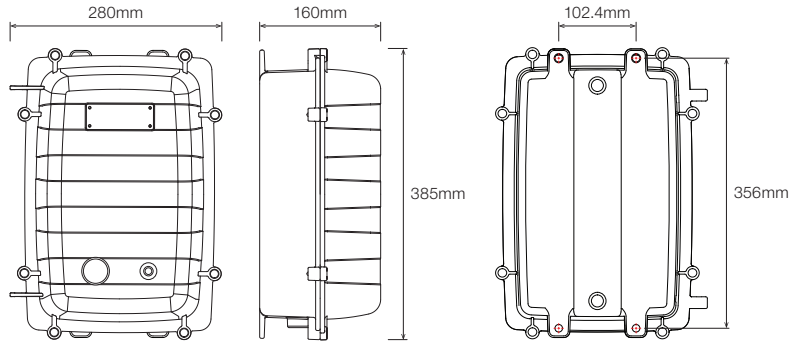

Mounting Bracket

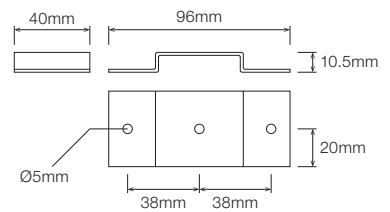

Stainless Steel Power Supply

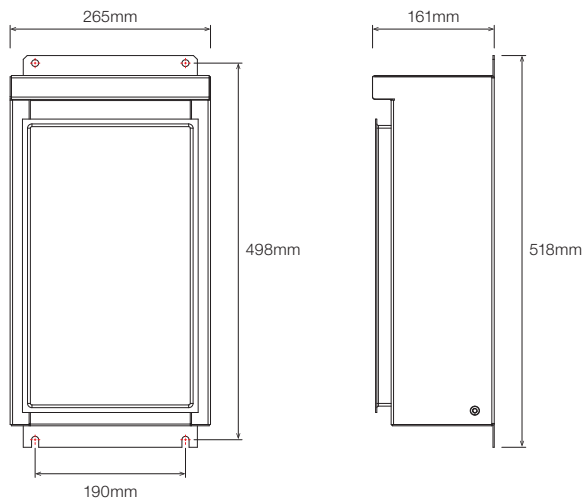

TECHNICAL SPECIFICATIONS

Product	ROM Hopper Bin Depth / Distance Indicator Light
Model	CST

Electrical Characteristics (Power Supply)

Model Part Number	PWR-AS2SBAR-WBLLS
Voltage Range	90 – 264VAC
Frequency Range	47 – 63Hz
Power Factor	0.94 / 230VAC
Leakage Current	<0.8mA / 240VAC

Electrical Characteristics (Luminaire)

Nominal Voltage	24VDC
Voltage Range	22 – 30VDC
Cable Type	UL2517 14#2C+18#1C Braid PVC UV Resistant, Black
Cable Diameter	7.5mm
Cable Length	3m

Environmental

IP Rating	IP66
Operating Temp. Range	-20 to +50°C
Thermal Management Type	Active/Continuous
Expected Lifespan	50,000 Hours to 70% Brightness
Material Composition (Body)	Aluminum Alloy (Marine Grade Black Anodized)
Material Composition (Optics)	Protective Polycarbonate Clear Cover
Material Composition (Bracket)	Stainless Steel 304 Brackets

Warranty

Warranty	3 years warranty as standard. 5 years extended warranty optional.
-----------------	--

¹ Reading taken while test unit operating in steady state. Ambient temperature during testing is typically 25°C. Individual unit behaviour may differ due to electronic component tolerance and ambient conditions. Product parameters and application suitability shall be checked by the user prior to commissioning.

CONFIGURATION

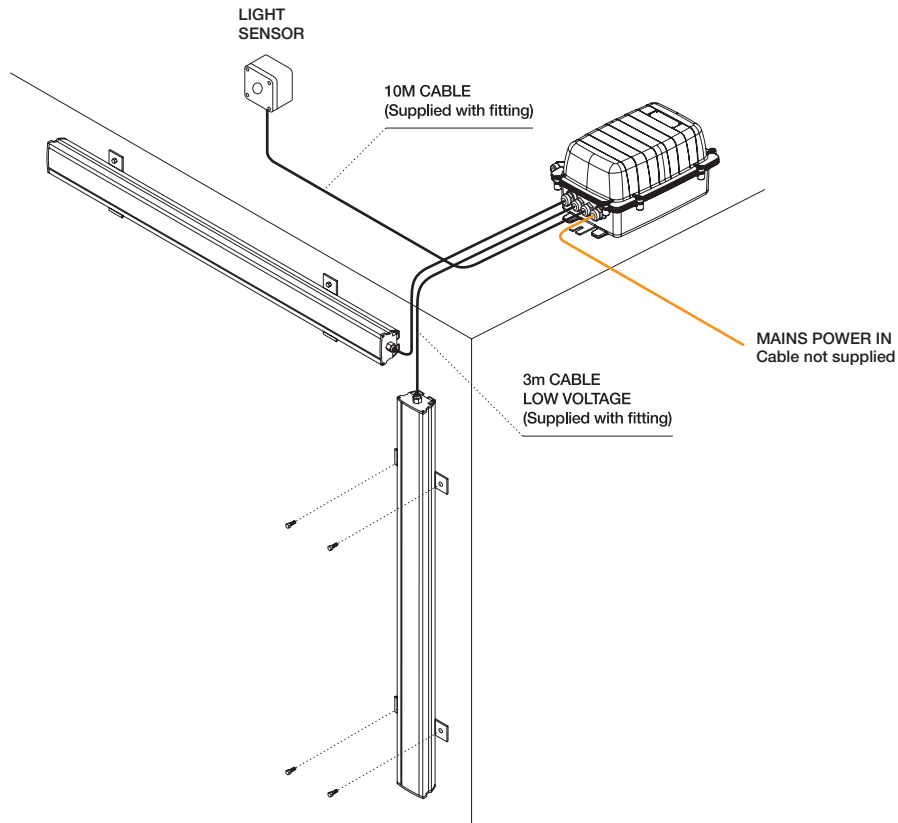

ROM HOPPER BIN LED KIT ¹

Kit Includes

- 1 x Light Bar Red/Amber/Green
- 1 x Light Bar Blue
- 1 x 230VAC Power Supply to suit 2 x Light Bars
- 1 x Day/Night Bi-Level Light Sensor

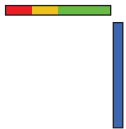

Part No.:

KIT - ROMBLED - R2A2G4BL8 - WPS - WLS

INDIVIDUAL PARTS

Light Bar Red/Amber/Green

Light Bar Red/Amber/Green with 30° optics
1450mm long



Part No.: **CST - LNHP - R2A2G4 - L30C**

Light Bar Blue

Light Bar 8 segments Blue with 30° optics
1450mm long



Part No.: **CST - LNHP - BL8 - L30C**

Power Supply in Standard Enclosure

230VAC Power supply to suit 2 Light Bars up to
200W total, with Bi-level light Sensor

Part No.: **PWR - AS2SBAR - WBLLS**

OPTIONAL UPGRADES

Wide Range Power Supply in Stainless Steel Enclosure ²

Wide Voltage Range Power Supply in Stainless
Steel Enclosure to suit 2 Light Bars,
with Bi-level light Sensor

Part No.: **PWR - SS2BAR - WBLLS**

Light Bar Red/Green

Light Bar half Red/half Green with
30° optics, 1450mm long



Part No.: **CST - LNHP - R4G4 - L30C**

Day/Night Sensor

Day/Night Bi-Level Light sensor

Part No.: **CST - BILVL - SEN - DN**

¹ as per RioTinto standard
² as per BHP standard