

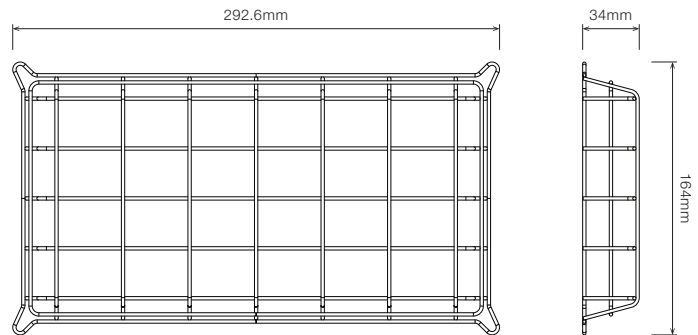

# BULKHEAD STAINLESS STEEL WIRE MESH GUARD

## Dimensions

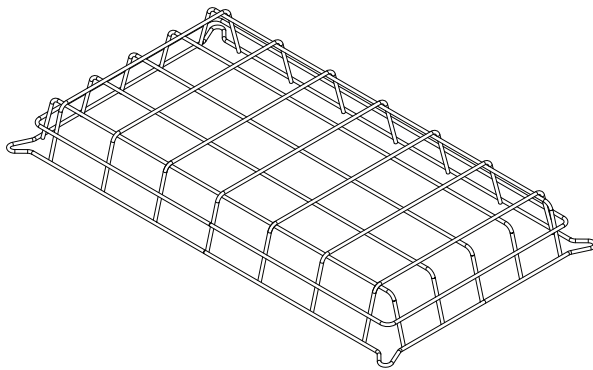

## Description

The Bulkhead Wire Mesh Guard has been designed to add an extra layer of protection from potential accidents/vandalism while minimising interference with light output.

## Technical Specifications

|                     |                             |
|---------------------|-----------------------------|
| <b>Suitable for</b> | Bulkhead LED Luminaire      |
| <b>Mounting</b>     | 4x M4x10 Screws and Washers |
| <b>Weight</b>       | 120g                        |

## Ordering Example

**ACC - BH - WMG**

Bulkhead Stainless Steel Wire Mesh Guard