

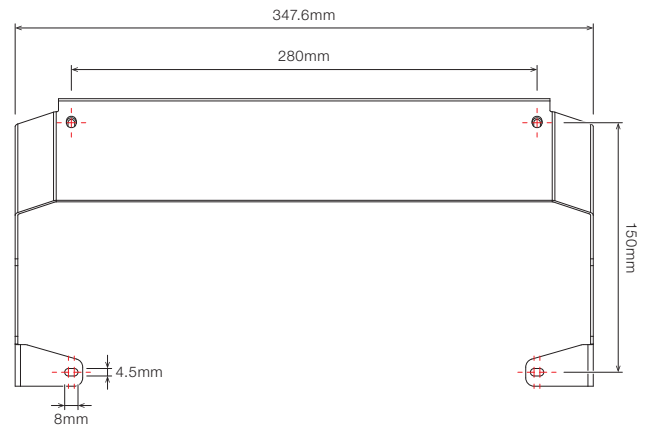

# BULKHEAD STAINLESS STEEL LIGHT SHIELD

## Dimensions

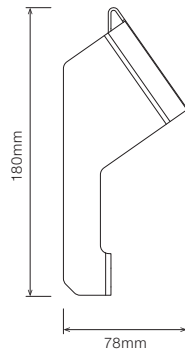
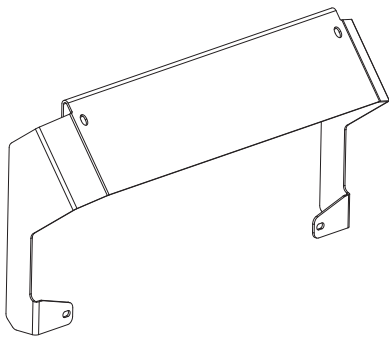

## Description

The Bulkhead Stainless Steel Light Shield is designed to reduce vertical light pollution.

## Technical Specifications

<b>Suitable for</b>	Bulkhead LED Luminaire
<b>Mounting</b>	4x M4x10 Screws and Washers
<b>Weight</b>	500g

## Ordering Example

### ACC - BH - SHIELD

Bulkhead Stainless Steel Light Shield