

EYE WASH STATION

INDUSTRIAL LED LUMINAIRE

Installation Instructions



Wherever possible, we aim to use recyclable packaging product. Please help us to care for the environment by disposing of all recyclable materials appropriately.

EYE WASH STATION LED LUMINAIRE Technical Specifications

Luminaire

Luminous Flux	300-400lm
Power Consumption (Including Power Supply)	11W Max
Operating Voltage	24VDC
Operating Temp. Range	-40°C +55°C
Wavelength	532nm (Green)
IP Rating	IP67
Body	SS304 and Polycarbonate Tube
Mounting	Spigot Mount (34mm)

Power Supply (External)

Input Voltage	85-264VAC 120-370VDC
Operating Temp. Range	-20°C +50°C
IP Rating	IP66

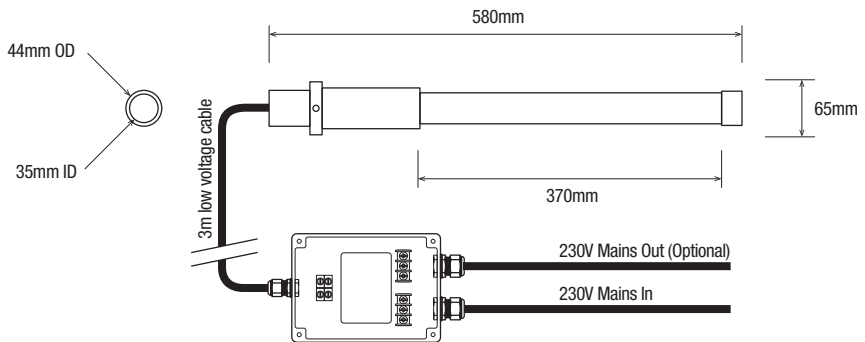

Installation Instructions

Step 1 Feed the cable through and slide the Eye Wash Station LED onto the spigot

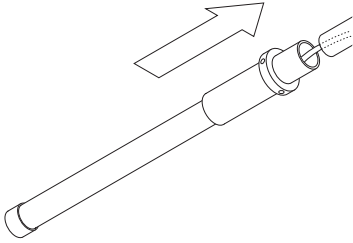

Step 2 Tighten bolts to secure luminaire to the spigot

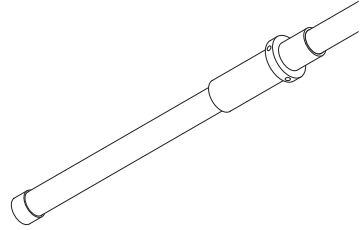

Step 3 Open up Power Supply unit and wire according to diagram below.

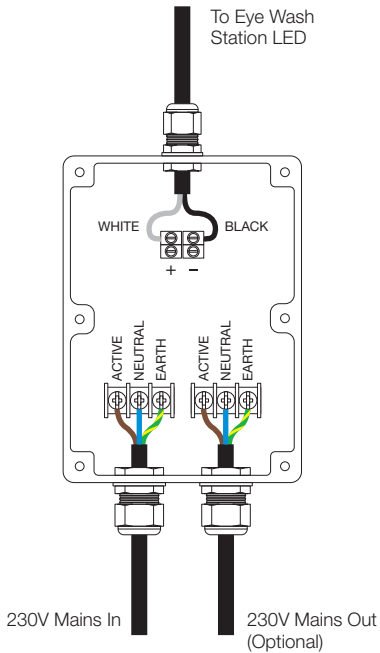

Step 4 Close and secure Power Supply unit

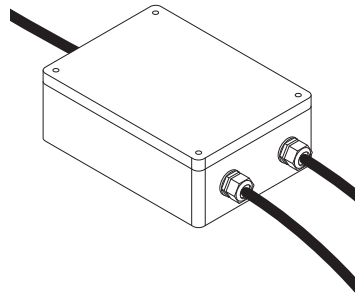



phone: +613 8681 3633 **fax:** +613 9703 2408
email: support@coolon.com.au **web:** www.coolon.com.au