

CP9 INDUSTRIAL LED LUMINAIRE

Installation Instructions



Wherever possible, we aim to use recyclable packaging product. Please help us to care for the environment by disposing of all recyclable materials appropriately.

CP9 Technical Specifications

Luminaire

Model	CP9	
LED Type	XM-L	XP-G
No. of LEDs	9	16
Luminous Flux	2830 - 3356 lm	2640-2888 lm
Power Consumption	42.0W Typical 43.3W Start	40.3W Typical 42.7W Start
Operating Voltage Range	19VDC - 35VDC (M) 12VDC - 35VDC (A)	
Operating Temp. Range	-40°C +55°C	
IP Rating	IP66	
Body	Aluminium Alloy (Anodized and E-Coated)	
Mounting Bracket	Stainless Steel 316	
Luminaire Weight	2.3kg	
STB Bracket Weight	0.39kg	
MPB Bracket Weight	0.47kg	

Included in box

- 1 x CP9 Unit
- 1 x Mounting Bracket
- 2 x Norlock Washers
- 2 x M10 Hex Screws

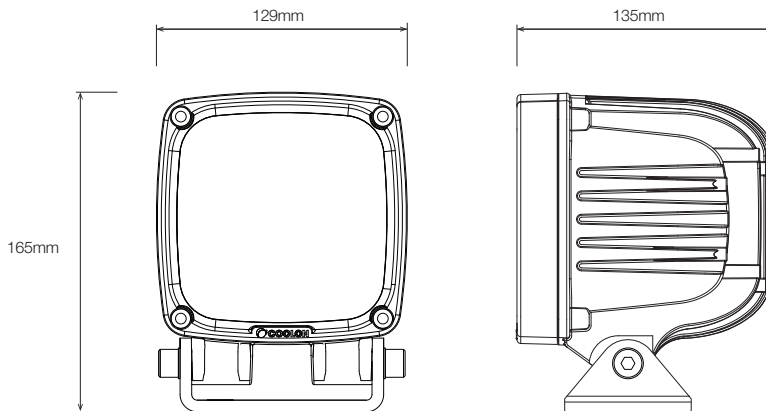

CP9 Installation

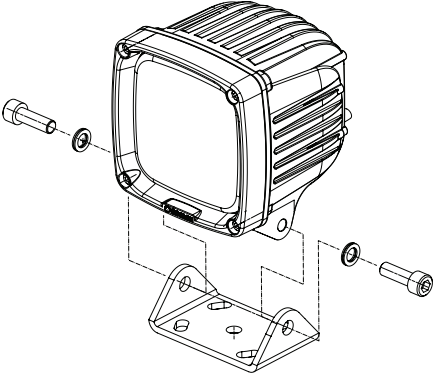

Adjust the mounting angle and secure the CP9 lamp to the mounting bracket using the Norlock Washers and M10 Hex Screws.

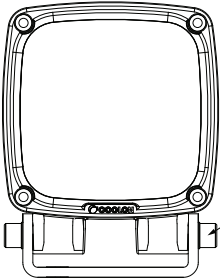

NOTE: RECOMMENDED TORQUE 37 N.M
MAX TORQUE 48 N.M

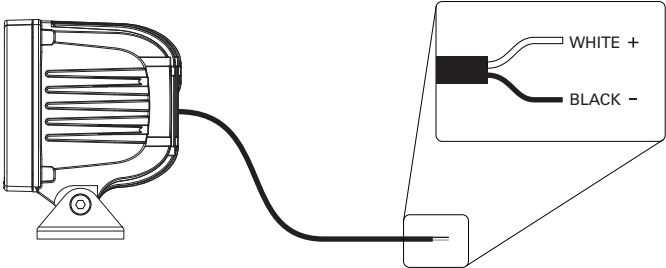

Connect to compatible Power Supply



phone: +613 8681 3633 **fax:** +613 9703 2408
email: support@coolon.com.au **web:** www.coolon.com.au