



## Applications

- High Bay
- Flood Light
- Area Lighting

Designed and manufactured in Australia using only the highest quality components, the CP96 High Power LED Luminaire is designed specifically for industrial applications where reliability and performance are paramount.

Able to work side by side with people in the harshest of environments and is ideally suited for most situations where bulb maintenance is difficult or impossible.

Every component of the CP96 LED luminaire has been carefully engineered to provide the most reliable performance and bring across many benefits of utilizing solid state lighting technology in industrial applications.

Coolon's range of industrial LED lighting products are backed by a 3 years manufacturer's warranty.

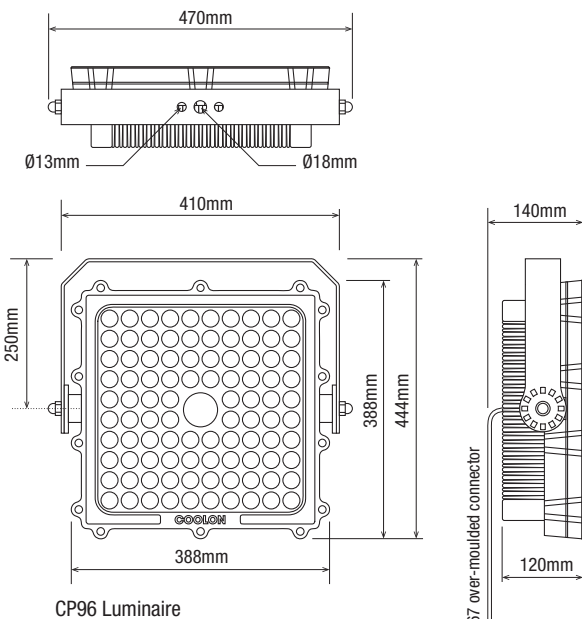

CP96 Luminaire

## Technical Specifications

Luminous Flux	8300 - 14000 lm
LED Efficacy	<90lm/w @ 25°C
Power Consumption (including power supply)	230W Max
Power Supply	24VDC 320W
Inrush Current	Cold Start 44A/230VAC
Current Consumption	11.2A Max
Max. Operating Voltage	26VDC
Min. Operating Voltage	23VDC
IP Rating	IP66
Power Factor	>0.9
Body	Aluminium Alloy (E-Coated)
Weight (Luminaire Only)	14.6kg
Angle adjustment	±90° in 30°steps
Mounting Bracket	Steel (Zinc Plated and E-Coated)
Luminaire Package Dimensions & Weight	460 x 420 x 154mm @ 15.8kg
Power Supply Package Dimensions & Weight	440 x 250 x 170mm @ 3.2kg

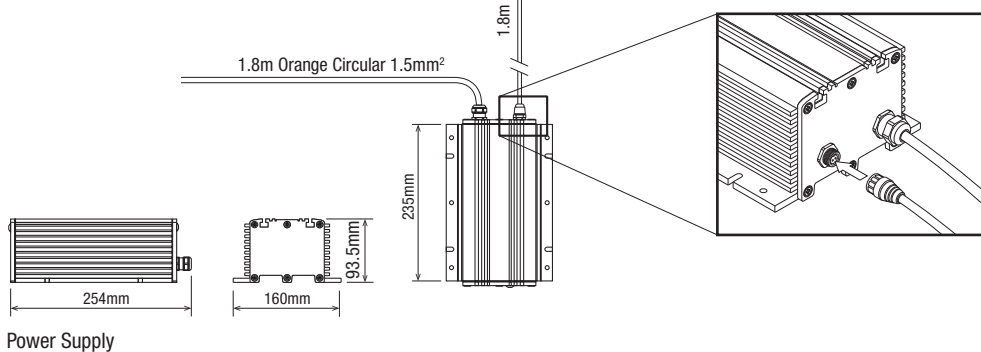

Power Supply

