



# NJZ HazLoc LED Luminaire Ranger Series



## CERTIFICATIONS & COMPLIANCES

- Class I Division 2, Group A, B, C, D
- Class II Division 1, Group E, F, G
- Class II Division 2, Group F, G
- Class III, Division 1
- Simultaneous Presence
- UL 1598A Marine Outside Type
- UL 1598 Wet Locations
- UL 844 Hazardous Locations
- UL 8750 LED Safety
- DLC

# NJZ-FEL-E



## Key Features:

- A** 130lm/W high luminous efficacy
- B** Die-cast aluminum housing with good heat dissipation
- C** Solid state design, vibration and shocks resistant
- D** Slim and light profile, convenient for mounting

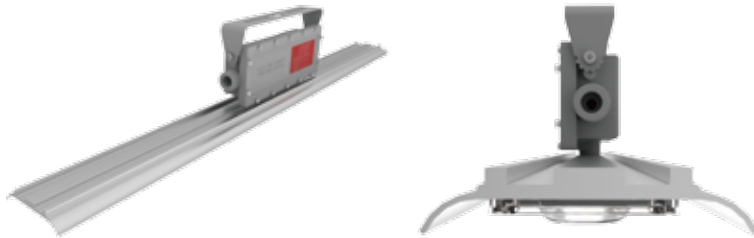

## Parameter

Model	C1D1	C1D2	Voltage	Ambient temperature	CCT	Fixture Lumens	Watt	LPW	Optical Pattern	Inlet Thread
NJZ-FEL-E-40		●	AC100-240/277V,200-480V	-40℃-+55℃	5000k	5200	40	130	110°	NPT3/4"
NJZ-FEL-E-80		●	AC100-240/277V,200-480V	-40℃-+55℃	5000k	10400	80	130	110°	NPT3/4"

## Mounting options

• Ceiling

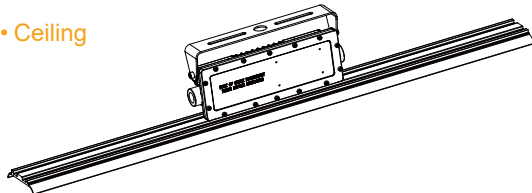

• Wall

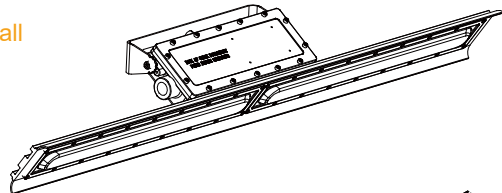

• Hanging chain

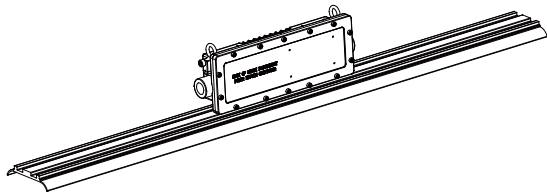

• Pole

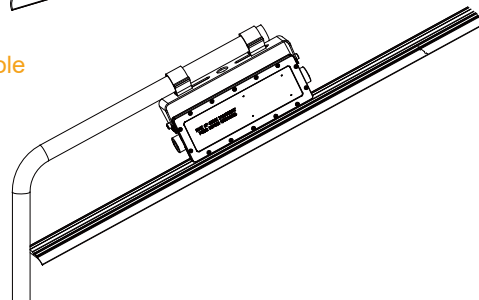

## Photometrics

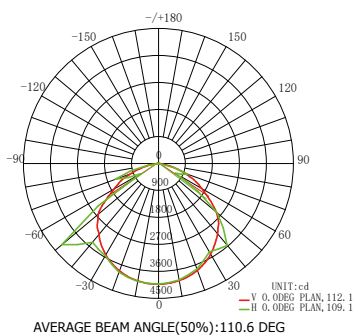

## Application



Gas Station



Chemical Processing Facility



Marine Loading Terminals



Manufacturing Plant



Address: No.58 Hengguang Road, Nanjing Economic Technological Development Zone, Nanjing, CHINA

Tel: +86-25-52397600-ext8816

Email: inquiry@njztech.com

Web: www.njzlighting.com