

INSTALLATION INSTRUCTIONS

Step 1

Feed the cable through and slide the DLK onto the spigot.

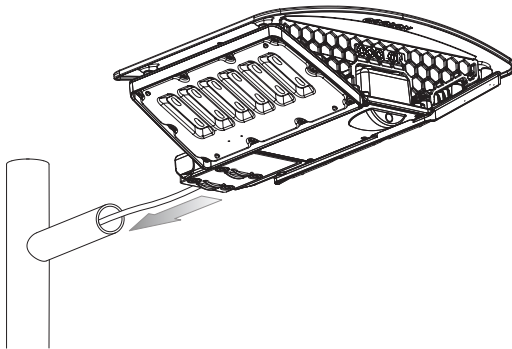

Step 2

Tighten bolts to secure luminaire to the spigot.

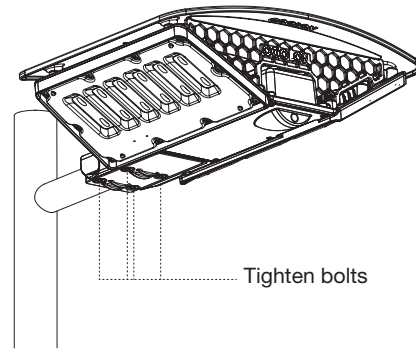

Step 3 *Optional U-Bolts

Mount the DLK to spigot by securing U-Bolts with washers and Nylock nuts.

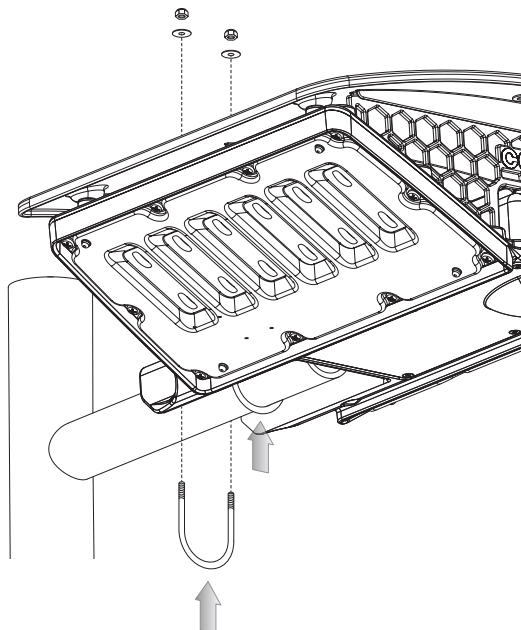

WIRING

Mains (100 ~ 240VAC) Version

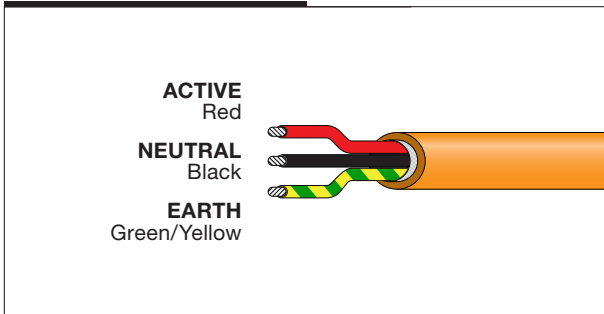

Low Voltage (24VDC) Version

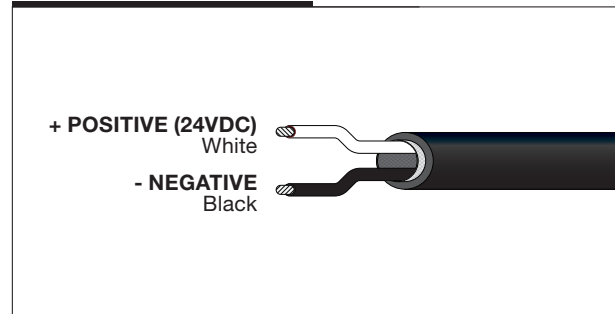

LIGHT SENSOR DIMMING

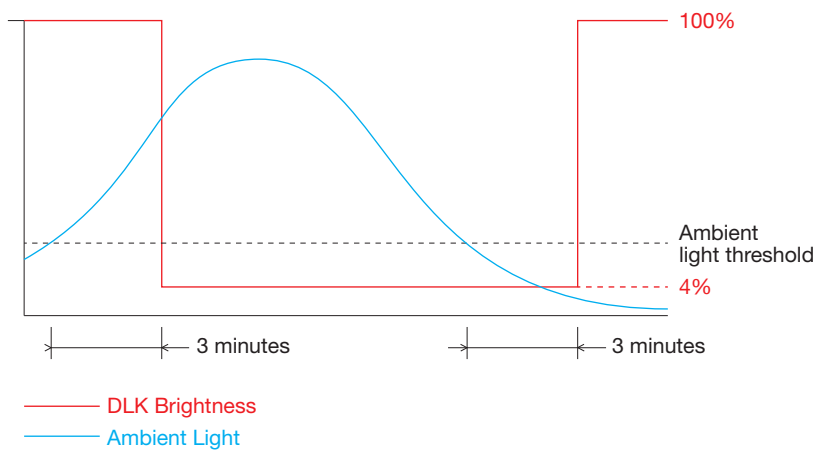

The DLK LED will be at 100% brightness when it is turned on and then will dim to 4% brightness when daylight is detected. 3 minutes after the daylight has dropped below the minimum ambient light threshold, the DLK LED will ramp up to 100% brightness. (Only applies to DLK equipped with light sensor)