

CP9 Luminaire w/ Standard Bracket

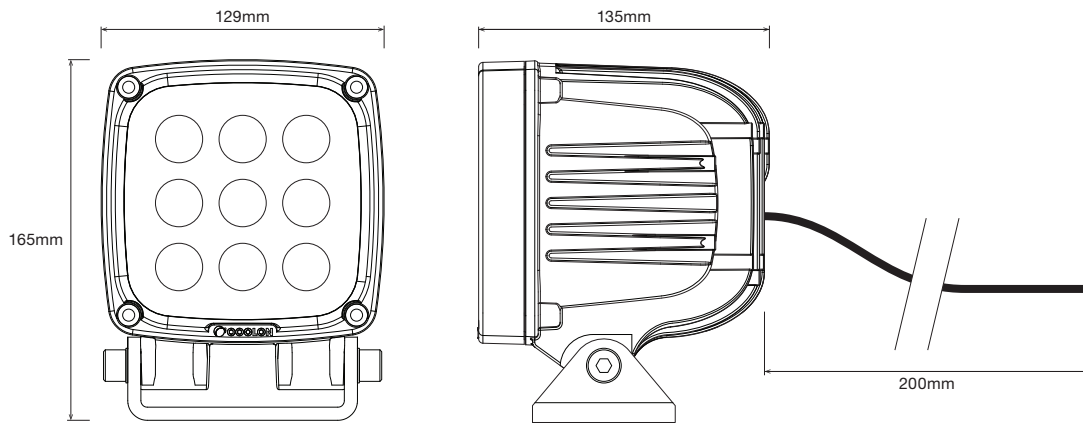

INSTALLATION INSTRUCTIONS

Step 1

Adjust the mounting angle and secure the CP9 lamp to the mounting bracket using the Norlock Washers and M10 hex screws.

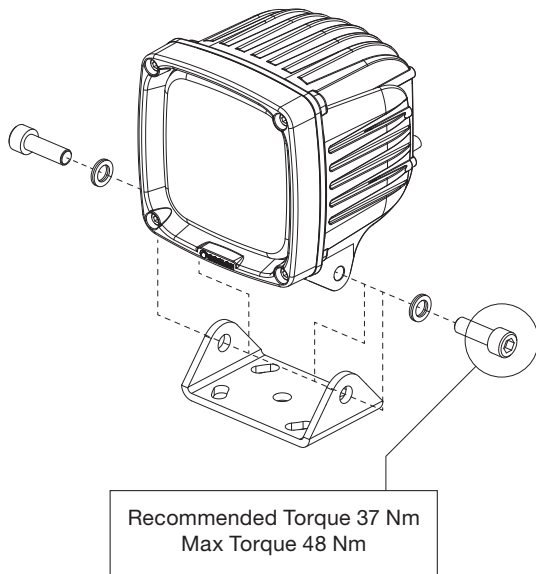

Step 2

Connect to compatible Power Supply.

