

**MOUNTING BRACKET INSTALLATION**

**Step 1**

Install arm locks onto protruding studs on both sides of the housing as shown below.

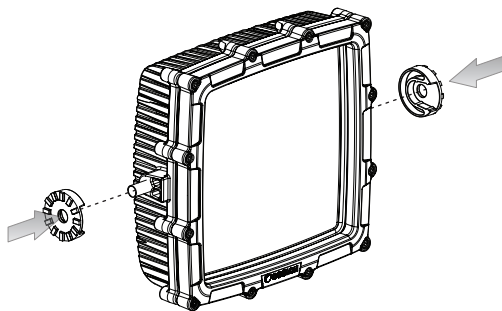

**Step 2**

Apply necessary force to open the bracket in order to fit over the properly positioned arm locks.

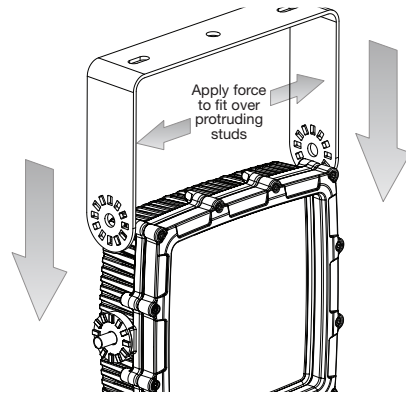

**Step 3**

Align perforated slots in mounting bracket against corresponding notches in the arm locks, then tighten the nut. Ensure that all the perforated slots sit firmly on the notches after tightening up the nuts. Recommended tightening torque is 40 Nm.

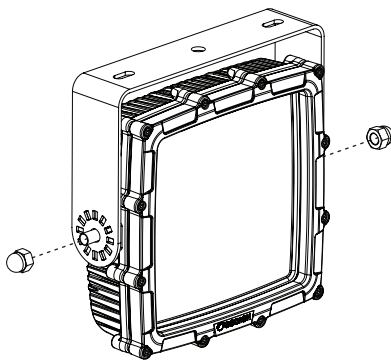

Please use Loctite® 243™ retaining compound (not included) to secure the dome nut.

**IMPORTANT:** Ensure that all perforated slots sit firmly on the notches after tightening up the dome nuts.

