



 COOLON

PATHLIGHT GUARDIAN™

10W Path Light

Pathlight Guardian™ LED luminaire is a durable path light that is ideal for use with solar panels to illuminate remote areas.

Made specifically to withstand the harshest environmental conditions, Pathlight Guardian™ LED luminaire offers reliable performance that will improve the safety of your neighborhood.

Pathlight Guardian™ is proudly designed and manufactured in Australia. It is easy to install and environmentally friendly. With special optics designed to focus its light distribution, Pathlight Guardian™ provides maximum illumination and minimum disruption to animals. With a marine grade stainless steel body, Pathlight Guardian™ is available in a range of colour temperatures.

Designed for use in:

- Path lighting
- Parks
- Walkways
- Car parks
- Jetties
- Remote area lighting



Robust & virtually indestructible

Pathlight Guardian™ LED luminaire has been specifically designed to withstand vandalism, eliminating the need for regular maintenance and making your neighbourhood safer.

Environmentally friendly & innovative

With its low energy consumption, Pathlight Guardian™ LED luminaire is ideal for use with solar panels in off-the-grid locations to illuminate streets, parks, walkways, parking lots, jetties and other public spaces.



INDUSTRIAL GRADE FINISHINGS

A long-life luminaire deserves a long-life finish. We source the finest 316 stainless steel to ensure the luminaire provides superior performance all year round. This luminaire is resistant to various elements including ultraviolet light, abrasion and corrosion.



NO FLICKERING

LED luminaires run on constant low voltage power and do not produce any visible stroboscopic effects, thus reducing the strain on eyes and significantly improving safety in areas where moving machinery is present.



LOW SUSCEPTIBILITY TO VIBRATION

This luminaire is designed to handle continuous exposure to vibration. A typically critical issue affecting the life and operation of most common gas discharge lamp based light sources is mechanical shock and vibration.

3
YEARS

3 YEARS FACTORY WARRANTY

Coolon Luminaires are covered by a solid comprehensible manufacturer's warranty that covers a range of possible defects and performance parameters throughout the duration of the warranty period.



INSTANT ON/OFF

LEDs do not require warm up. Instant on to 100% output translates to no downtime, improved safety and the ability to utilize sensor switching to significantly save energy.

IP66

HIGH IP RATING - IP66

Coolon's Industrial LEDs are designed specifically to withstand the harsh conditions in mining environments. The robust design allows our LED products to be used in many different applications and are high pressure washable.

L70

LONG USEFUL OPERATING LIFE

Currently available specification from world's most reputable LED manufacturers states 50,000 hours of continuous operation at the rated current within the operating temperature range to 70% residual light output.



PROUDLY MADE IN AUSTRALIA

Engineered to perfection, using only the highest quality components and highly skilled labour, each luminaire is assembled and thoroughly tested to ensure that it exceeds the highest standards.

DIMENSIONS

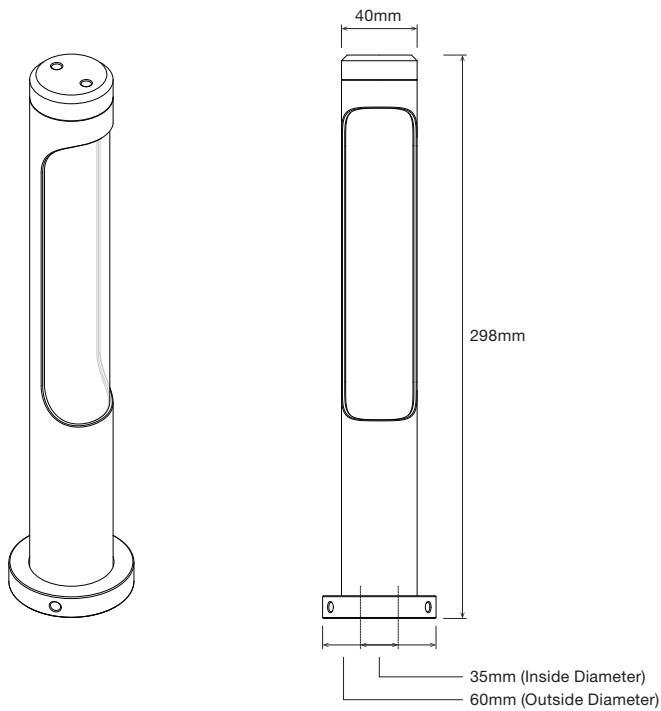

TECHNICAL SPECIFICATIONS

Product

Model Pathlight Guardian™

Optical Characteristics

Luminous Flux (Photometered) 1000 – 1300 lm

Luminous Flux (LED Lumens) 1300 lm

CCT WWT 2700 – 3500K

CWT 4300 – 6500K

CRI >70

Electrical Characteristics (Luminaire)

Power Consumption 9.6W

Nominal Voltage 12VDC / 24VDC

Voltage Range 11 – 50VDC

Cable Type UL2095, 16 AWG x 2C Braid PVC, UV Resistant

Cable Diameter 7.5mm

Cable Length 7m

Environmental

IP Rating IP66

Impact Rating IK09

Salt Spray Tested Yes

Operating Temp. Range -20 to +50°C

Thermal Management Type Active/Continuous

Expected Lifespan 50,000 Hours to 70% Brightness

Material Composition (Body) Stainless Steel 316

Material Composition (Diffuser) Polycarbonate

Weight/Packaging

Luminaire Weight 0.8kg (L) 1.5kg (L+C)

Packaging Dimensions 380x140x70mm

Packaging Weight 1.7kg

Warranty

Warranty 3 years warranty as standard
5 years extended warranty optional

SUPPLY VOLTAGE VS POWER

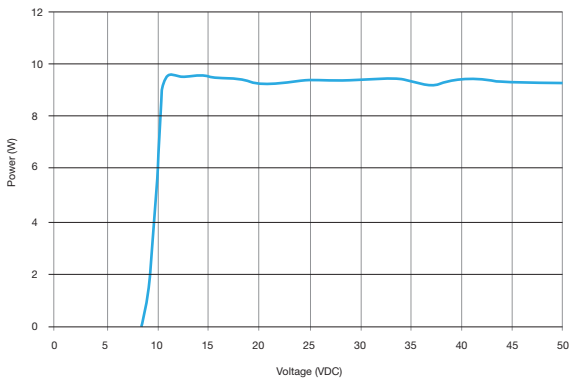

COLOUR TEMPERATURES

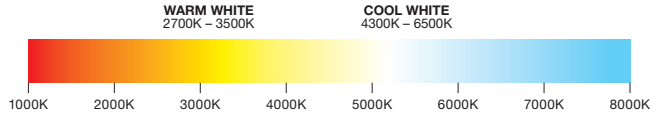

All colour temperatures are indicative. Some variation can occur.

OPTICAL DISTRIBUTION

F5010 Flare 100° x 20° Beam Angle

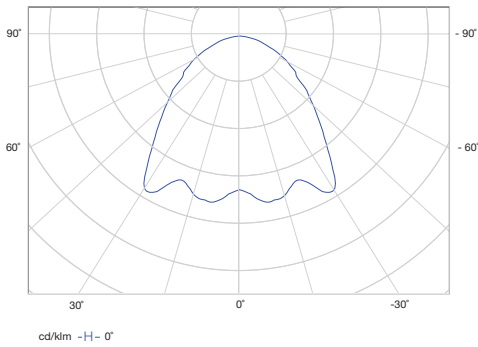

F5010 Flare 100° x 20° Beam Angle

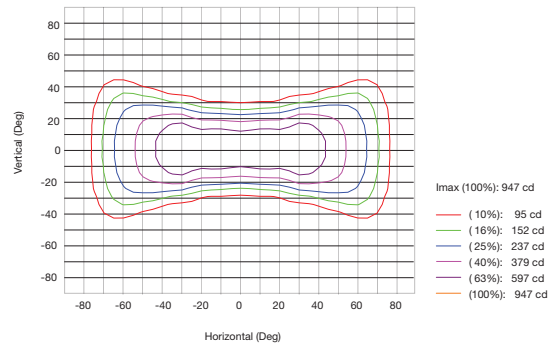

ORDERING EXAMPLE

PLG - CWT - F5010 - ELV

PRODUCT COLOUR TEMP OPTICS SUPPLY OPTION

PRODUCT	COLOUR TEMP	OPTICS	SUPPLY OPTION
Pathlight Guardian™	CWT Cool White LEDs WWT Warm White LEDs	F5010 Flare 100° x 20° Beam Angle	ELV Extra Low Voltage Luminaire