



 COOLON

# EMERGENCY PACK

240W Battery Pack



## LOW SUSCEPTIBILITY TO VIBRATION

The Emergency Pack is designed to handle continuous exposure to vibration. Designed specifically to be mounted away from the luminaire to minimize the weight of the luminaire and effects of mechanical shock and vibration.



## EXTENSIVE FACTORY WARRANTY

Coolon Products are covered by a comprehensible manufacturer's warranty that covers a range of possible defects and performance parameters throughout the duration of the warranty period.

IP66

## HIGH IP RATING - IP66

Coolon's Industrial Products are designed specifically to withstand the harsh conditions in mining environments. The robust design allows our units to be used in many different applications and are high pressure washable.



## PROUDLY MADE IN AUSTRALIA

Engineered to perfection, using only the highest quality components and highly skilled labour, each luminaire is assembled and thoroughly tested to ensure that it exceeds the highest standards.

### DLK/TNR AMBIENT TEMP VS POWER

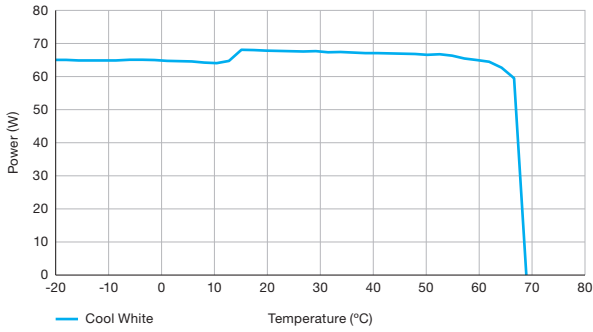

### DLK/TNR POWER VS RUN TIME\*

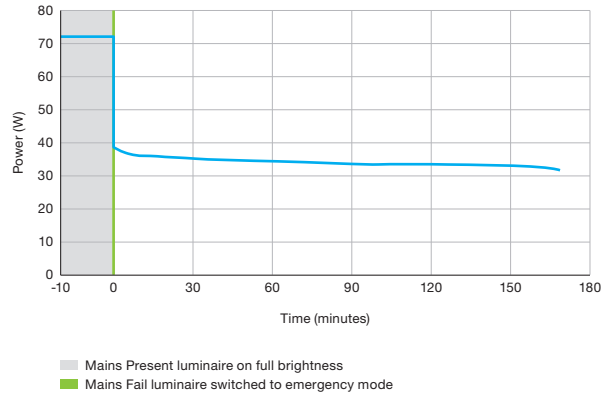

\*Emergency pack wired according to maintain mode

### DIMENSIONS

#### LM6 Aluminium Alloy

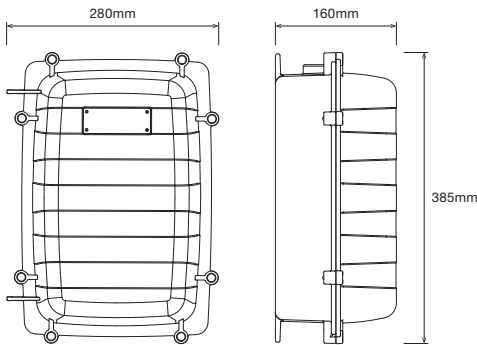

#### Stainless Steel 316

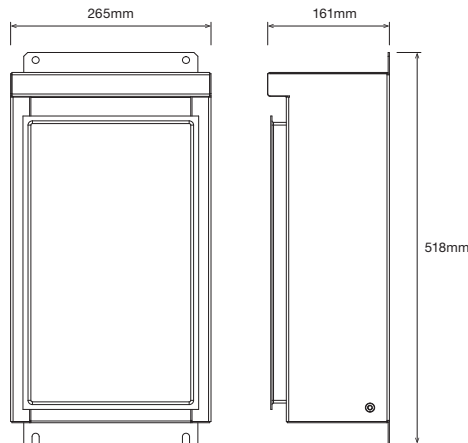

#### Mounting Bracket

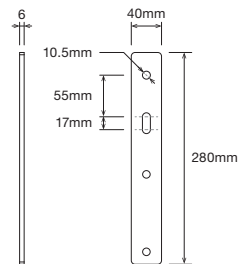

### TECHNICAL SPECIFICATIONS

#### Make/Model

Model	Emergency Pack AL	Emergency Pack SS
Part Number	EMP-724-036AL	EMP-724-093SS

#### Electrical Characteristics

Power Consumption	240W
Nominal Voltage	230VAC
Voltage Range	90 ~ 305VAC, 127 ~ 431VDC
Frequency Range	47- 63Hz
Power Factor	>0.95 / 230VAC
Leakage Current	<0.7mA / 277VAC
Cable Gland Diameter	10 ~ 12mm
Charge Time	8 hours
Battery Type	SLA/VRLA
Battery Manufacturer	Panasonic
Battery Capacity	12V 7.2Ah / 20HR
Number of Batteries per Unit	2
Discharge Time	Over 2 hours

#### Environmental Characteristics

IP Rating	IP66
Salt Spray Tested	Yes
Operating Temp. Range	0 ~ +50°C
Material Composition (Body)	LM6 Aluminium Alloy (<0.1% copper content)   Stainless Steel 316

#### Weight/Packaging

Unit Dimensions	400 x 280 x 180mm	518 x 265 x 161mm
Unit Weight	10.2kg	14.3kg

#### Warranty

Control Gear	3 Years
Batteries	2 Years